

# CLARKE®



## AIR COMPRESSOR XE RANGE - ELECTRIC MOTOR DRIVE

### OPERATION & MAINTENANCE INSTRUCTIONS



ORIGINAL INSTRUCTIONS

DL07/24 - ISS 7

# INTRODUCTION

Thank you for purchasing this CLARKE compressor which is designed to supply compressed air to air powered tools for a wide range of applications such as spraying, sanding, drilling and cutting.

Before attempting to use this product, please read this manual thoroughly and follow the instructions carefully. In doing so you will ensure the safe operation of the compressor. Please note, these compressors are for indoor use only.

## MODELS COVERED

Model Number	Air output	Max working pressure	Receiver capacity	Motor HP	Weight	Dimn's (mm)	Sound Power level dB (LWA)	Sound Pressure level dB (LAEQ)
XEP15/50	14cfm	10.3bar	50L	3HP	61kg	930 x430 x800	101	78
XEPV16/50	14cfm	10.3bar	50L	3HP	66kg	930x430 x 800	99	77
XEPVH16/50	14cfm	10.3bar	50L	3HP	71kg	1000x460 x 840	99	77
XE15/150	14cfm	10.3bar	150L	3HP	88kg	1330x420 x 850	98	81
XEV16/100	14cfm	10.3bar	100L	3HP	69kg	1130x360 x 830	98	82
XEV16/150	14cfm	10.3bar	150L	3HP	86kg	1330x42x 850	101	84
XEV16/200	14cfm	10.3bar	200L	3HP	100kg	1460x470 x 910	101	84
XE18/200	18cfm	10.3bar	200L	4HP	98kg	1460x470 x 910	104	87
XE25/200	23cfm	10.3bar	200L	5.5HP	127kg	1460x470 x 990	102	84
XE29/270	28cfm	10.3bar	270L	2x3HP	150kg	1570x515 x1040	105	87
XE36/C200	30cfm	10.3bar	200L	7.5HP	122kg	1450x450 x1000	110	92.3
XE37/270	36cfm	10.3bar	270L	2x4HP	151kg	1570x515 x1040	106	88

---

## **RESIDUAL RISK**

---

Although this manual contains extensive safety warnings and information on the safe operation of your compressor, every tool does have certain residual risks which cannot be completely excluded with warnings or safety devices. This compressor must therefore always be operated with caution.

---

## **GUARANTEE**

---

This product is guaranteed against faulty manufacture for a period of 12 months from the date of purchase. Please keep your receipt which will be required as proof of purchase.

This guarantee is invalid if the product is found to have been abused or tampered with in any way, or not used for the purpose for which it was intended.

Faulty goods should be returned to their place of purchase, no product can be returned to us without prior permission.

This guarantee does not effect your statutory rights.

---

## **ENVIRONMENTAL RECYCLING POLICY**

---



Through purchase of this product, the customer is taking on the obligation to deal with the WEEE in accordance with the WEEE regulations in relation to the treatment, recycling & recovery and environmentally sound disposal of the WEEE.

In effect, this means that this product must not be disposed of with general household waste. It must be disposed of according to the laws governing Waste Electrical and Electronic Equipment (WEEE) at a recognised disposal facility.

---

## **SPARE PARTS AND DIAGRAMS**

---

Spare parts and diagrams are available on request by contacting our parts and service department on 020 8988 7400.

---

# SAFETY PRECAUTIONS

---

Before using your compressor it is in your own interest to read and pay attention to the following safety rules:

1. **COMPRESSED AIR IS DANGEROUS - NEVER** direct a jet of air at people or animals.
2. **DO NOT** operate your air compressor with any guards removed.
3. Electrical or mechanical repairs should only be carried out by a qualified electrician/engineer. If you have a problem, contact your local dealer, or our Service Department on 020 8988 7400
4. Before attempting any repair ensure pressure is expelled from the air receiver and disconnect from electrical supply.
5. **DO NOT** leave pressure in air receiver overnight or when transporting.
6. **DO NOT** adjust or tamper with any safety valves. The maximum working pressure of the compressor is clearly stated on the machine.
7. Take care when transporting the machine to avoid tipping the machine over.
8. **DO NOT** operate in a wet/damp environment.
9. Locate your air compressor on a firm flat surface with AVMs and ensure an adequate supply of clean air is available to the pump unit.
10. **DO NOT** exert any strain on electrical cables and ensure that air hoses are not tangled or wrapped around machinery etc.
11. The cylinder head and delivery pipes of your compressor become quite hot during operation. **DO NOT** touch. After switching off remember to leave an adequate cool-down period before touching.
12. Ensure that any equipment/tool used in conjunction with your compressor has a safe working pressure exceeding the output pressure of the machine.
13. When disconnecting air hoses or other equipment from your compressor ensure that the air supply is turned off at the machine outlet and expel all pressurised air from within the air hose and other equipment attached to it.
14. If using your compressor for paint spraying:
  - **NEVER** spray close to any source of flame or heat.
  - **ALWAYS** ensure the spraying area has adequate fresh air ventilation.
  - Hazardous paints require special apparatus (see paint manufacturers recommendations).
15. **NEVER** let people use unless they have had the necessary training.
16. Permanently installed pipe-work systems should be designed and installed by a competent engineer.

---

# INSTALLATION

---

Before installing your machine check that its air output is sufficient for the equipment to be used. The air output from the compressor must be more than the volume of air required. We recommend the following:

1. Select a firm and level site and use of floor mountings for stationary compressors with anti-vibration pads. (Do not bolt machines directly to the floor).



**WARNING: MOVE THE COMPRESSOR ON A PALLET OR USING SLINGS BENEATH THE RECEIVER NEAR TO THE DOMED ENDS, EMPLOYING A FORK LIFT TRUCK OR WHEELED GANTRY CRANE. BEWARE OF OFF CENTRE LOADS. THE WEIGHT OF THE COMPRESSOR IS SHOWN ON THE DATA TABLE ON PAGE 2.**

---

2. Select a dust and damp free environment.
3. Allow adequate ventilation for:-
  - The air intake for the compressor pump.
  - Cooling air for the compressor pump and electric motor.
4. Allow sufficient access for servicing. A minimum clearance of 500mm must be allowed around the machine.
5. The power cable from the main power supply must be adequate to carry the starting and running load of the electric motor. This is particularly relevant if the compressor is some distance from the source of the supply.
6. Electrical installations should be completed by a qualified electrician.
7. Electrical connection to the mains power supply must be via a suitably fused (see table on page 6) approved plug or isolator (allowing sufficient capacity for motor starting). If using a circuit breaker, ensure it is motor rated and of sufficient size to allow for motor starting.
8. Compressors should be connected to mains electricity supply via an earth leakage protection device (RCD).

## ELECTRICAL CONNECTIONS

Connect the mains power lead through a suitably fused isolator to a 230 Volt (50Hz) electrical supply with a fuse rating as listed in the table below.

See wiring label on the power cable.

- All models must be run from the power supply stated below.

**WARNING: A STANDARD 13 AMP PLUG MUST NOT BE USED WITH THESE COMPRESSORS.**

- Both XE29/270 and XE37/270 are supplied with a sequential direct on-line starter.

Model Number	Motor HP	Supply Voltage	Supply Amperage required
XEP15/50	3HP	230V/1PH	30 Amp
XEPV16/50	3HP	230V/1PH	30 Amp
XEPVH16/50	3HP	230V/1PH	30 Amp
XE15/150 - OL	3HP	230V/1PH	30 Amp
XE15/150 - WIS	3HP	400V/3PH	16 Amp
XEV16/100 - OL	3HP	230V/1PH	30 Amp
XEV16/150 - OL	3HP	230V/1PH	30 Amp
XEV16/150 - WIS	3HP	400V/3PH	16 Amp
XEV16/200 - OL	3HP	230V/1PH	30 Amp
XE18/200 - OL	4HP	230V/1PH	40 Amp
XE18/200 - WIS	4HP	400V/3PH	20 Amp
XE25/200 - WIS	5.5HP	400V/3PH	25 Amp
XE29/270 - OL	2 x 3HP	230V/1PH	30 Amp
XE36C200 - WIS	7.5HP	400V/3PH	30 Amp
XE37/270 - OL	2 x 4HP	230V/1PH	40 Amp

- WIS = Wired in starter
- OL = overload protection

---

## BEFORE STARTING

---

1. Check the compressor pump oil level using (a) dipstick (to the level marked) or (b) the sight glass (see fig.1)
2. For lubrication of the pump use Clarke compressor oil as indicated on the machine data plate.
3. Check the Automatic Control:- Pressure switch ON/OFF switch is in the OFF position.

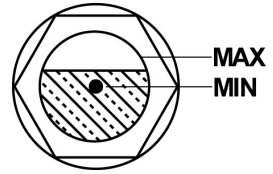

---

### WARNING:



- 1. BEFORE STARTING THE COMPRESSOR, OPEN ALL OUTLET VALVES.**
  - 2. THE FOLLOWING START AND STOP INSTRUCTIONS MUST BE FOLLOWED IN THE CORRECT SEQUENCE TO AVOID SERIOUS DAMAGE TO THE COMPRESSOR/MOTOR.**
- 

## STARTING THE COMPRESSOR

1. Switch on the mains power supply.
2. Switch on the pressure switch (lift the knob or twist the switch). (See "GENERAL ARRANGEMENT" on page 8., item 22)
3. Check the rotation (Flywheel/Fan blows air over the pump)
4. Check that the pressure does not exceed the maximum working pressure (stamped on machine data plate). If the pressure exceeds the maximum working pressure stated, stop the machine (see below), vent the system and contact the Clarke Service Department.

## STOPPING COMPRESSOR

1. Switch off at the pressure switch (Push the knob down or turn the switch).
  2. Isolate from the power supply.
  3. Drain the air receiver (release drain tap).
- 



**WARNING: THE COMPRESSOR PUMPS DELIVERY PIPES WILL REMAIN HOT FOR SOME TIME AFTER USE.**

---

**NOTE:** When starting compressors up to and including the 3HP models, an 'auto bleed' valve will operate and air will be heard venting. This is quite normal and should not cause concern. The valve should close after several seconds. Should it fail to close, consult your Clarke dealer.

# GENERAL ARRANGEMENT

**NB: Must be mounted on Anti Vibration Pads**

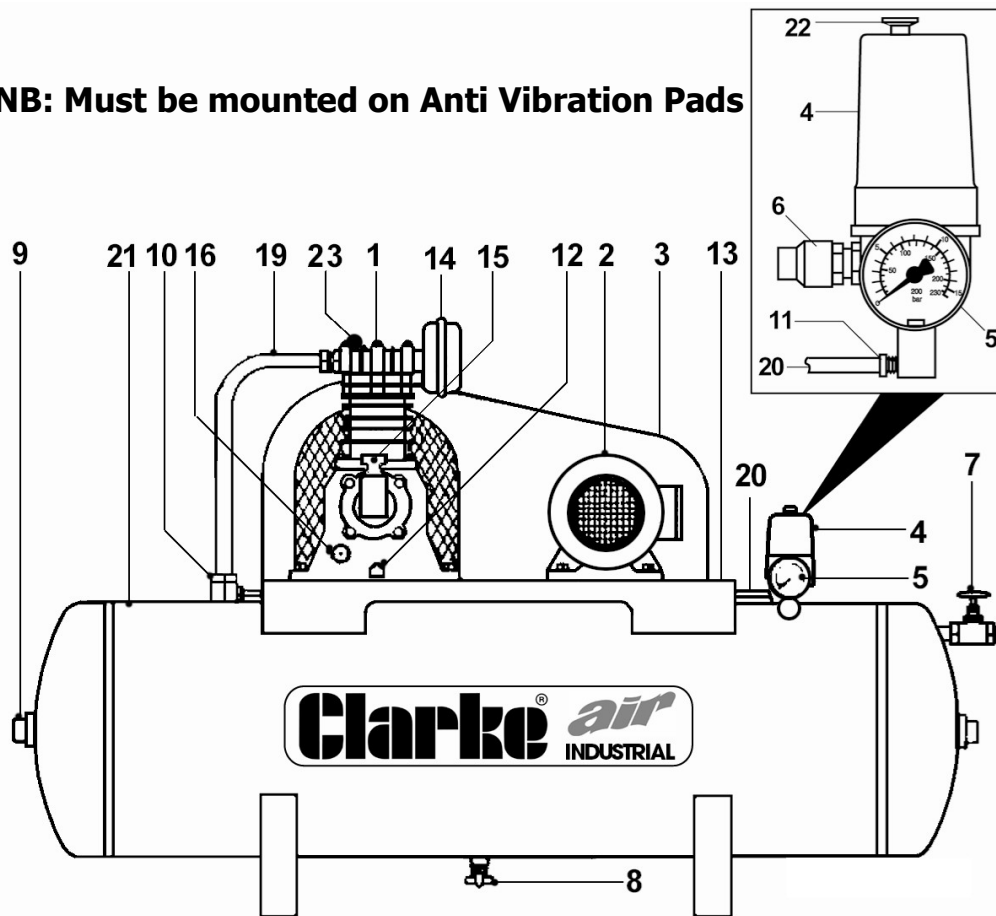

Fig.2

**Illustrative purposes only**

1	Air Compressor Pump	9	Inspection Plug	17	N/A
2	Electric Motor	10	Non-return Valve	18	N/A
3	Wire Guard	11	Air Bleed Valve	19	Air Delivery Pipe
4	Pressure Switch	12	Oil Drain Plug	20	Air Bleed Pipe
5	Pressure Gauge	13	Saddle	21	Air Receiver
6	Safety Valve	14	Air Intake Filter	22	On/Off switch
7	Ball Valve	15	Oil Filler/Breather	23	Auto Air Bleed
8	Drain Tap	16	Oil Level Sight Glass		

**NOTE:** On automatic machines an Auto Star Delta (ASD) starter may be fitted, ready to be mounted to a wall or panel etc. It is IMPORTANT to note that NO ADJUSTMENTS should be made to this component. The ASD should be connected to a 3-phase supply by a qualified electrician.



# OUTLET PRESSURE ADJUSTMENTS

## PORTABLE COMPRESSORS

1. Pressure adjusting knob
2. Outlet taps
3. Pressure gauge

### TO ADJUST THE OUTLET PRESSURE:

To increase pressure - turn the knob (1) clockwise. To decrease pressure - turn the knob (1) anti-clockwise.

Outlet taps - slide the knurled section (2) away from the body to open and push towards the body to close.

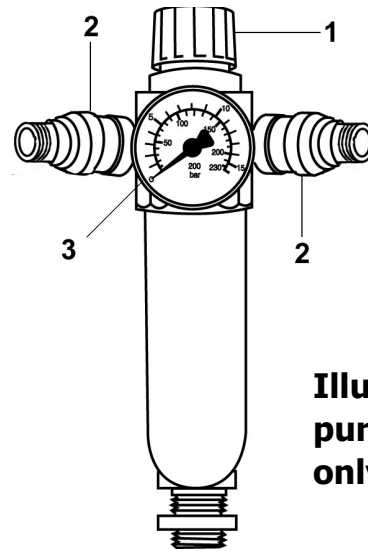

**Illustrative  
purposes  
only**

**NOTE:** The pressure shown on the Pressure Gauge (3) will differ by approx 1 bar depending on whether the outlets are open/closed.

## STATIONARY COMPRESSORS

These machines are not supplied with the facility to adjust outlet pressure. A comprehensive range of airline accessories is available from your local CLARKE stockist.

## OVERLOAD BUTTON (SINGLE PHASE ONLY)

The electric motor is fitted with an automatic overload detector which will stop the motor if an overload is detected.

If this happens;

1. **SWITCH OFF THE PRESSURE SWITCH** (Push knob down or turn switch).
  - Allow the compressor to cool down for 5-10 minutes.
2. Press the Reset button shown on the right.
3. Switch on the pressure switch (lift knob or twist switch).

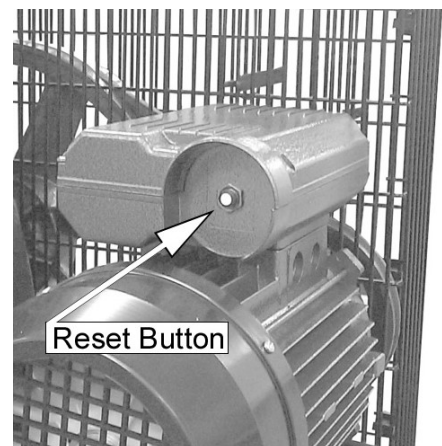

If the overload trips repeatedly it may indicate a fault with the compressor. In this case you should contact the Clarke service department.

# TROUBLESHOOTING

## ***IMPORTANT:***

1. Any remedial work that may be required must be carried out by a qualified electrician/engineer.
2. Disconnect from the mains power supply before removing any parts from the compressor.
3. Empty the air receiver of air before dismantling any part of the compressor unit's pressure system.
4. If your compressor develops a fault, do not use until the fault has been rectified.

<b>SYMPTOM</b>	<b>PROBABLE CAUSE</b>	<b>REMEDY</b>
Compressor will not start automatically	Fault in electrical installation	Let an electrician check electrical installation.
	Current supply failure.	
	Voltage drop.	
	Motor starter faulty.	
	Motor incorrectly connected or faulty	
	Starter overload has tripped out.	Reset by depressing button.
	Pressure switch defective.	Have pressure switch changed by an electrician.
	Fuse blown.	Check fuse rating - replace.
Compressor unit will not stop automatically.	Pressure switch defective.	Contact Clarke Service
Fuses keep blowing.	Inadequate size fuse installed.	Replace with reference to chart See page 6.
	Fault in motor.	Contact Clarke Service
Fuse keeps tripping	13amp plug fitted	These machine should be hard wired to a suitable power supply.
Bleed valve under pressure switch blows whilst compressor is not running	Non-return valve leaking.	Clean non-return valve or replace.

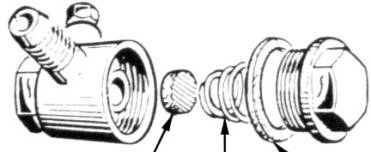
<b>SYMPTOM</b>	<b>PROBABLE CAUSE</b>	<b>REMEDY</b>
Bleed valve under pressure switch blows whilst compressor is running	Non return valve stuck (NRV) open at junction of the tank and the pump delivery pipe.	Drain tank and remove inspection nut to clean Non Return valve   Valve Spring Gasket
Compressor unit starts, but stops again after only a few revolutions.	Non-return valve leaking (compressor unit is on load during start).	Disconnect from the mains supply and empty air receiver. Clean or replace
	Non-return valve blocked, possibly frozen up.	Thaw non-return valve out (Unit must be installed in frost-free place).
	Solenoid valve leaking or defective (only applies to 10 HP machines and above).	Contact Clarke Service
Unusual noise from compressor	Bolts loose.	Tighten bolts.
	V-Belt, flywheel or cooling coil touching belt guard	Find place of contact and remedy fault.
	Flywheel loose.	Tighten flywheel.
	Unit installed on an unsuitable base.	Move unit to a more solid base
	Bearings, piston rings or cylinder worn.	Contact Clarke Service
	Valve broken.	Contact Clarke Service
	Bearings of electric motor worn	Contact Clarke Service
Compressor unit starts and stops more frequently than usual.	Large amount of condensation in air receiver.	Drain off condensation AT LEAST once a week.
	Leaks in control unit or inspection cover.	Locate leaks (by means of soapy water) and repair.
	Too little pressure differential.	Contact Clarke Service

<b>SYMPTOM</b>	<b>PROBABLE CAUSE</b>	<b>REMEDY</b>
Compressor's oil consumption rising.	Too much oil in compressor.	Check oil level 2 or 3 minutes after stopping.
	Leaks around crank case.	Contact Clarke Service
	Working temperature of compressor too high because of insufficient cooling.	Increase ventilation to air compressor.
	Unit too small in proportion to air consumption.	Connect supplementary.
	Semi-automatic unit load too small.	Convert to fully automatic operation.
	Cylinder worn	Contact Clarke Service
	Intake air filter blocked.	Clean / Change air filter.
Compressor runs continuously and can't attain the working pressure required.	Suction filter blocked.	Change filter.
	V-belt too slack (not applicable to direct drive machines).	Tighten V-Belt.
	Leak between compressor block and air receiver/ leaks in or near air receiver.	Tighten connection and repair leak or Contact Clarke Service
	RPM too low due to incorrectly connected electric motor.	Contact Clarke Service
	Valves blocked by dirt, paint, dust or coked up.	Contact Clarke Service
	Inspection cover or plug leaking	Empty air receiver and change seal or Contact Clarke Service
	Suction rendered difficult or impossible at suction intake or the air being taken in is too warm.	Ensure unobstructed air flow around the unit.
	Pressure gauge defective.	Replace
	Unit too small in relation to air consumption of connected equipment	Install a larger compressor
	Compressor worn.	Have compressor overhauled or replace it.
Compressor unit starts when no air is being used.	Leaks in pipework system	Locate and repair leaks.

<b>SYMPTOM</b>	<b>PROBABLE CAUSE</b>	<b>REMEDY</b>
Machine running but not pumping air into receiver (10HP only)	Air exhausting from solenoid after starter has changed direction from star to delta.	Check solenoid valve
		Contact Clarke Service
Compressor becomes too hot	Insufficient ventilation	See that sufficient air is supplied to flywheel or fan of compressor and that hot air is properly vented.
	Oil level too low (check 2 or 3 times after stopping).	Fill with oil - See page 7.
	Fault in valves (machine not stopping).	Contact Clarke Service
	Blown head gasket (machine not stopping).	Contact Clarke Service
	Dirt on cooling fins or suction filter.	Clean cooling fins and suction filter.
	Unit working at too high a pressure	Contact Clarke Service
	Non-return valve partly blocked.	Clean or thaw out non-return valve.
	Compressor being overworked and running continuously.	Use a larger compressor
Oil in the air delivered	Sump over full	Reduce oil to correct level
	Cylinder worn	Contact Clarke Service
	Intake air filter blocked	Change air filter
Condensation in crank case (especially in 2-stage compressors).	Compressor over dimensioned (operational periods too short in relation to resting periods).	Frequent oil changes. Reduce cooling of crank case (e.g. by shielding it from the air stream). Contact Clarke Service
Condensation at outlet points	Piping installation is incorrect	Consult your local dealer
	Compressor is taking in air that is too warm	Obtain better fresh air supply for the compressor.
	Delivery temperature of air from air receiver is too high	Use a larger air receiver
		Contact Clarke Service
Electric motor too hot: Maximum temperature 90°C (194°F).	Operational voltage too low	Call an electrician
	Faults in electrical installation	Contact Clarke Service
	Cooling fins of electric motor blocked by dirt	Clean cooling fins

## ROUTINE MAINTENANCE PLAN

CHECK LIST	DAILY	WEEKLY	6 MONTHLY	NOTES
Oil level	Check		Change	
Air receiver	Drain			
Intake filter		Check/clean		Replace if necessary
Oil breather		Check/clean		
Fan and cooling fins		Clean		
Non return valve		Clean	Replace if worn	
Belt Tension			Check/adjust Replace if worn	Does not apply to direct drive

### OTHER PRODUCTS WITHIN OUR RANGE

In addition to Air Compressors from 3–40 cfm, we offer a vast range of air tools and airline equipment. Please ask your local dealer for details of our range or a copy of our Power Products Catalogue.

# DECLARATION OF CONFORMITY



**Clarke**<sup>®</sup>  
**INTERNATIONAL**

Fitzwilliam Hall, Fitzwilliam Place, Dublin 2

## DECLARATION OF CONFORMITY

**This is an important document and should be retained.**

**We hereby declare that this product(s) complies with the following legislation:**

- 2014/30/EU Electromagnetic Compatibility Directive.*
- 2006/42/EC Machinery Directive.*
- 2011/65/EU Restriction of Hazardous Substances (amended by (EU) 2015/863).*
- 2014/29/EU Simple Pressure Vessel Directive.*
- 2000/14/EC Noise Emissions Directive, (amended by 2005/88/EC).*

**The following standards have been applied to the product(s):**

- EN 1012-1:2010, EN 61000-6-1:2007, EN IEC 61000-6-3:2021, EN 61000-3-2:2014,*
- EN 61000-3-3:2013, EN 62321:2013, EN 62321-2:2014, EN 62321-3-1:2014,*
- EN 62321-4:2014+A1:2017, EN ISO 3744:1995.*

The technical documentation required to demonstrate that the product(s) meet(s) the requirement(s) of the aforementioned legislation has been compiled and is available for inspection by the relevant enforcement authorities.

**The CE mark was first applied in: 2021**

**Date of Issue:** 12/09/2021

**Signed:**

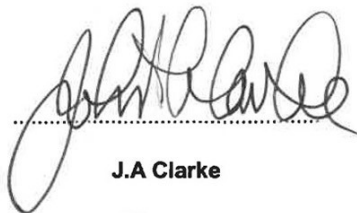

**J.A Clarke**

**Director**

# A SELECTION FROM THE VAST RANGE OF

# Clarke®

## QUALITY PRODUCTS



**AIR COMPRESSORS**  
From DIY to industrial, Plus air tools, spray guns and accessories.

**GENERATORS**  
Prime duty or emergency standby for business, home and leisure.

**POWER WASHERS**  
Hot and cold, electric and engine driven - we have what you need

**WELDERS**  
Mig, Arc, Tig and Spot. From DIY to auto/industrial.

**METALWORKING**  
Drills, grinders and saws for DIY and professional use.

**WOODWORKING**  
Saws, sanders, lathes, mortisers and dust extraction.

**HYDRAULICS**  
Cranes, body repair kits, transmission jacks for all types of workshop use.

**WATER PUMPS**  
Submersible, electric and engine driven for DIY, agriculture and industry.

**POWERTOOLS**  
Angle grinders, cordless drill sets, saws and sanders.

**STARTERS/CHARGERS**  
All sizes for car and commercial use.



## PARTS & SERVICE: 0208 988 7400

**Parts Enquiries**  
[Parts@clarkeinternational.com](mailto:Parts@clarkeinternational.com)

**Servicing & Technical Enquiries**  
[Service@clarkeinternational.com](mailto:Service@clarkeinternational.com)

SALES: UK 01992 565333 or Export 00 44 (0)1992 565335

**Clarke** INTERNATIONAL Hemnall Street, Epping, Essex CM16 4LG  
[www.clarkeinternational.com](http://www.clarkeinternational.com)